



2022

Ranchmanship
Scoresheets

ARHA Ranchmanship Scoring

1/2 Point Penalties

- A. Failure to remain more the 20 ft from fence when stopping or doing a rollback
- B. Starting a lope departure at a jog or exiting rollbacks up to 2 strides
- C. Delaying lead change by 1 stride
- D. Over or under spinning by 1/8 of a turn
- E. Each tick of a log, pole, cone, or obstacle.
- F. During run around failure to be on correct lead around bend but before half around

1 Point Penalties

- A. Each time out of lead deduct 1 point/ accumulative for each 1/4 of circle. See rulebook
- B. Over or under spinning by 1/4 turn
- C. During rundown to end of arena, failure to change leads beyond 1 stride but prior to next maneuver
- D. Hit or step on log, pole, or obstacle
- E. Break gait at walk or jog 2 strides or less, both feet on space, split pole on lope over.
- F. Skipping over or failing to step in to required space.
- G. Incorrect number of strides.

2 Point Penalties

- A. Break of gait
- B. During the run to the end of arena, failure to change leads beyond halfway around
- C. Jogging beyond 2 strides, but less than ½ circle or ½ of the arena
- D. Failure to go beyond markers or sliding past markers/cones
- E. Freeing up in spins or rollbacks

3 Point Penalties

- A. Break of gait at walk or jog for more than 2 strides
- B. Out of lead or break of gait at lope
- C. Knocking down or severely disturbing an obstacle
- D. Stepping outside the confines of or falling or jumping off or out of obstacle with one foot. Missing/evading pole that is part of a series of obstacles.

5 Point Penalties

- A. Spurring in front of the cinch
- B. Use of free hand to instill fear
- C. Holding saddle with free hand
- D. Kicking out
- E. Dropping an object required to be carried on course
- F. First and second refusals
- G. Balk or attempt to evade an obstacle by shying or backing more than 2 strides away
- H. Stepping outside the confines of, falling or jumping off or out of an obstacle with designated boundaries with more than one foot once the foot has entered the obstacle; including missing one element of an obstacle on a line of travel with two feet.
- I. Failure to demonstrate correct gait between obstacle as designated

Zero Score

- A. Failure to complete pattern
- B. Performing maneuvers in unspecified order
- C. Inclusion of additional maneuvers
- D. Equipment failures
- E. Balking or running away
- F. Jogging more than ½ circle of ½ arena length while starting a circle, circling
- G. Overspins of more than ¼ turn
- H. Fall to ground by horse or rider
- I. More than 1 finger between reins or more than 1 hand on reins except for Junior horses ridden with snaffle/hackamore or mecate with snaffle
- J. Blatant disobedience, bucking, rearing, etc.

Faults not to be considered disqualifications but should be scored according to severity:

- A. Crooked stops and backs
- B. Anticipated stops
- C. Uncontrollable speed
- D. Wringing of tail
- E. Knocking over markers
- F. Failure to run pattern within markers
- G. Failure to go past markers on said pattern
- H. Opening mouth, raising head on stops and turns.

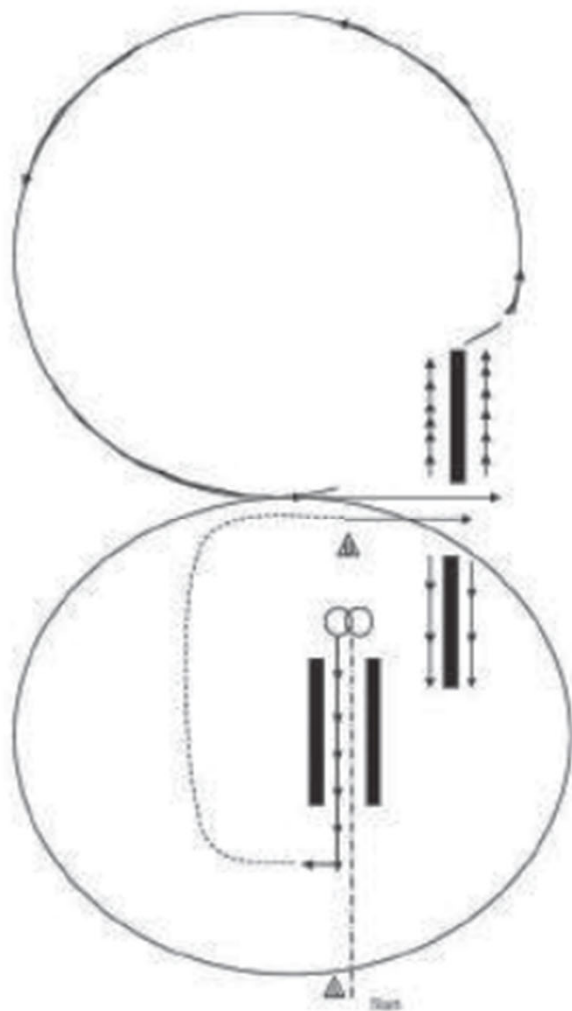

Ranchmanship Pattern #1

1. Extended Trot From Cone through chute; Stop.
2. 1 spin left.
3. 1 spin right.
4. Back through chute 1/4 turn left.
5. Trot to cone.
6. At cone walk to side pass pole.
7. Side pass left.
8. Lope left lead.
9. Change to right lead.
10. Lope right circle; Stop at side pass pole.
11. Side pass right.

American Ranch Horse Association Ranchmanship Score Sheet

Pattern #1

ARHA rev 2021

Class Name: _____

1/2 Point Penalties:

- A. Failure to remain more the 20 ft from fence when stopping or doing a rollback
- B. Starting a lope departure at a jog or exiting rollbacks up to 2 strides
- C. Delaying lead change by 1 stride
- D. Over or under spinning by 1/8 of a turn
- E. Each tick of a log, pole, cone, or obstacle.
- F. During run around failure to be on correct lead around bend but before half around

1 point Penalties

- A. Each time out of lead deduct 1 point/ accumulative for each 1/4 of circle. See RuleBook
- B. Over or under spinning by 1/4 turn
- C. During rundown to end of arena, failure to change leads beyond 1 stride but prior to next maneuver
- D. Hit or step on log, pole, or obstacle
- E. Break gait at walk or jog 2 strides or less, both feet on space, split pole on lope over.
- F. Skipping over or failing to step in to required space.
- G. Incorrect number of strides.

2 Point Penalties

- A. Break of gait
- B. During the run to the end of arena, failure to change Leads beyond halfway around
- C. Jogging beyond 2 strides, but less than 1/2circle Or 1/2 the arena
- D. Failure to go beyond markers/ or sliding past markers or cones
- E. Freezing up in spins or rollbacks

5 Point Penalties

- A. Spurring in front of the cinch
- B. Use of free hand to instill fear
- C. Holding Saddle with free hand
- D. Kicking Out
- E. Dropping an object required to be carried on course.
- F. First and second refusals
- G. Balk or attempt to evade an obstacle by shying or backing more than 2 strides away
- H. Stepping outside the confines of, falling or jumping off or out of an obstacle with designated boundaries with more than one foot once the foot has entered the obstacle; including missing one element of an element of an obstacle on a line of travel with two feet.
- I. Failure to demonstrate correct gait between obstacle as designated.

-0- Score

- A. Failure to complete Pattern
- B. Performing Maneuvers in unspecified order
- C. Inclusion of additional maneuvers
- D. Equipment Failures
- E. Balking or running away
- F. Jogging more than 1/2 circle or 1/2 Arena length while starting a circle, circling
- G. Over spins of more than 1/4 turn
- H. Fall to ground by horse or rider
- I. More than 1 finger between reins or more than 1 hand on reins except for Junior horses ridden with snaffle/hackamore or mecate with snaffle
- J. Blatant disobedience, bucking, rearing, etc.

Faults not to be considered disqualifications but should be scored according to severity:

- A. Crooked stops & backs
- B. Anticipated stops
- C. Uncontrollable speed
- D. Wringing of tail
- E. Knocking over markers
- F. Failure to run pattern within markers
- G. Failure to go past markers on said pattern
- H. Opening mouth, raising head on stops and turns

Maneuver Description	Extend trot thru chute; stop	1 Spin Left	1 Spin Right	Back chute 1/4 L	Trot to cone	Sidepass L	Lope Left Lead	Change	Lope Right Circle; stop at pole	Sidepass R							HMS	MVT	Penalty Total		
Back #	Penalty																				PLACING
	Score																				
Back #	Penalty																				PLACING
	Score																				
Back #	Penalty																				PLACING
	Score																				
Back #	Penalty																				PLACING
	Score																				
Back #	Penalty																				PLACING
	Score																				
Back #	Penalty																				PLACING
	Score																				
Back #	Penalty																				PLACING
	Score																				

DATE _____

JUDGES SIGNATURE _____

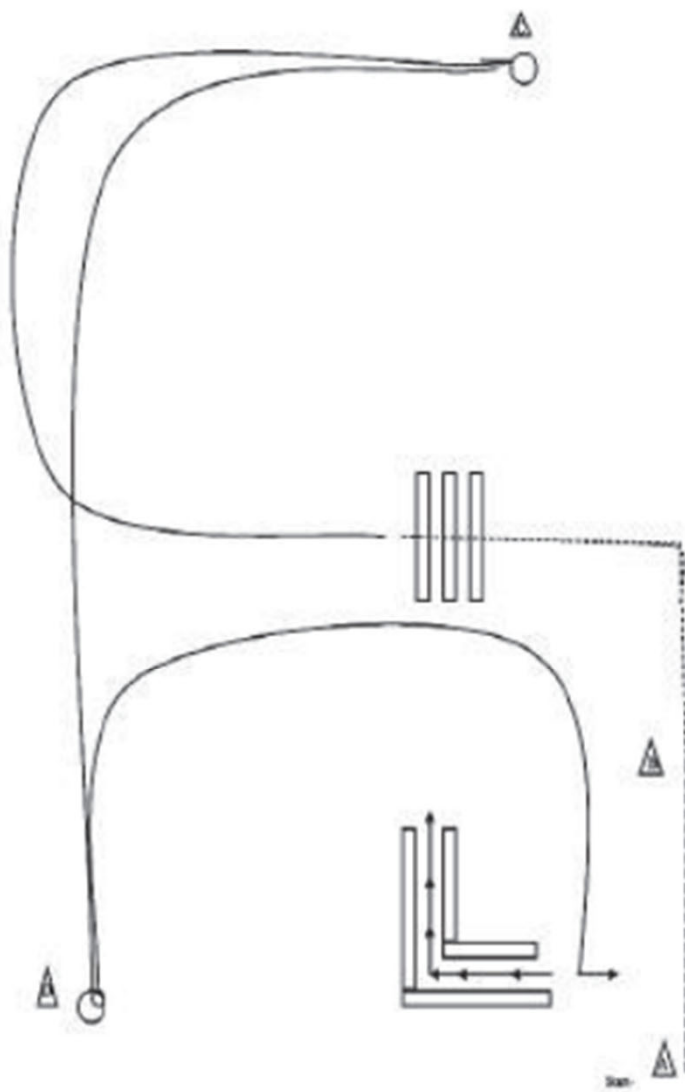

Ranchmanship Pattern #2

1. Walk A-B.
2. At cone trot to and over cross poles.
3. After poles are cleared Right lead lope.
4. At Cone ;Stop.
5. 1½ spin left.
6. Left lead lope to cone; Stop.
7. 1½ spins right.
8. Lope right lead to chute; Stop; 90° turn.
9. Back thru Chute.

American Ranch Horse Association Ranchmanship Score Sheet

Pattern #2

ARHA rev 2021

Class Name: _____

1/2 Point Penalties:

- A. Failure to remain more than 20 ft from fence when stopping or doing a rollback
- B. Starting a lope departure at a jog or exiting rollbacks up to 2 strides
- C. Delaying lead change by 1 stride
- D. Over or under spinning by 1/8 of a turn
- E. Each tick of a log, pole, cone, or obstacle.
- F. During run around failure to be on correct lead around bend but before half around

1 point Penalties

- A. Each time out of lead deduct 1 point/ accumulative for each 1/4 of circle. See RuleBook
- B. Over or under spinning by 1/4 turn
- C. During rundown to end of arena, failure to change leads beyond 1 stride but prior to next maneuver
- D. Hit or step on log, pole, or obstacle
- E. Break gait at walk or jog 2 strides or less, both feet on space, split pole on lope over.
- F. Skipping over or failing to step in to required space.
- G. Incorrect number of strides.

2 Point Penalties

- A. Break of gait
- B. During the run to the end of arena, failure to change Leads beyond halfway around
- C. Jogging beyond 2 strides, but less than 1/2circle Or 1/2 the arena
- D. Failure to go beyond markers/ or sliding past markers or cones
- E. Freezing up in spins or rollbacks

5 Point Penalties

- A. Spurring in front of the cinch
- B. Use of free hand to instill fear
- C. Holding Saddle with free hand
- D. Kicking Out
- E. Dropping an object required to be carried on course.
- F. First and second refusals
- G. Balk or attempt to evade an obstacle by shying or backing more than 2 strides away
- H. Stepping outside the confines of, falling or jumping off or out of an obstacle with designated boundaries with more than one foot once the foot has entered the obstacle; including missing one element of an element of an obstacle on a line of travel with two feet.
- I. Failure to demonstrate correct gait between obstacle as designated.

-0- Score

- A. Failure to complete Pattern
- B. Performing Maneuvers in unspecified order
- C. Inclusion of additional maneuvers
- D. Equipment Failures
- E. Balking or running away
- F. Jogging more than 1/2 circle or 1/2 Arena length while starting a circle, circling
- G. Over spins of more than 1/4 turn
- H. Fall to ground by horse or rider
- I. More than 1 finger between reins or more than 1 hand on reins except for Junior horses ridden with snaffle/hackamore or mecate with snaffle
- J. Blatant disobedience, bucking, rearing, etc.

Faults not to be considered disqualifications but should be scored according to severity:

- A. Crooked stops & backs
- B. Anticipated stops
- C. Uncontrollable speed
- D. Wringing of tail
- E. Knocking over markers
- F. Failure to run pattern within markers
- G. Failure to go past markers on said pattern
- H. Opening mouth, raising head on stops and turns

Maneuver Description	Walk A-B	Trot to & Over poles	RL Lope	Stop	1 1/2 Left	LL Lope	Stop	1 1/2 Right	Lope RL to chute	Stop: 90 turn	Back chute				HMS	MVT	Penalty Total		
Back #	Penalty																		PLACING
	Score																		
Back #	Penalty																		PLACING
	Score																		
Back #	Penalty																		PLACING
	Score																		
Back #	Penalty																		PLACING
	Score																		
Back #	Penalty																		PLACING
	Score																		
Back #	Penalty																		PLACING
	Score																		
Back #	Penalty																		PLACING
	Score																		

DATE _____

JUDGES SIGNATURE _____

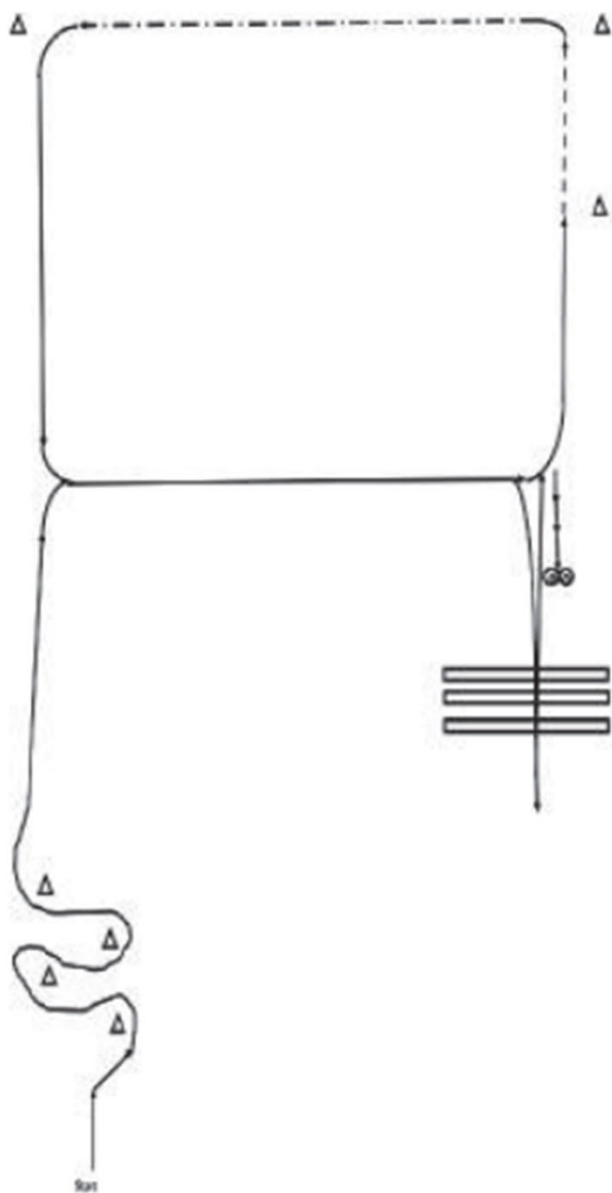

Ranchmanship Pattern #3

1. Trot Serpentine through the cones.
2. Clear last cone; Right Lead Lope.
3. In Center Change to Left Lead.
4. Lope to cone; transition to walk.
5. Walk to next cone.
6. Extended Trot to next cone.
7. Pick up left lead to center.
8. Change to right.
9. Lope through crossover.
10. Stop, Roll Back Left.
11. Lope Back through lope over.
12. Stop Back 8-10 feet.
13. 2 Spins Right.
14. 2 Spins Left.

American Ranch Horse Association Ranchmanship Score Sheet

Pattern #3

ARHA rev 2021

Class Name: _____

1/2 Point Penalties:

- A. Failure to remain more the 20 ft from fence when stopping or doing a rollback
- B. Starting a lope departure at a jog or exiting rollbacks up to 2 strides
- C. Delaying lead change by 1 stride
- D. Over or under spinning by 1/8 of a turn
- E. Each tick of a log, pole, cone, or obstacle.
- F. During run around failure to be on correct lead around bend but before half around

1 point Penalties

- A. Each time out of lead deduct 1 point/ accumulative for each 1/4 of circle. See RuleBook
- B. Over or under spinning by 1/4 turn
- C. During rundown to end of arena, failure to change leads beyond 1 stride but prior to next maneuver
- D. Hit or step on log, pole, or obstacle
- E. Break gait at walk or jog 2 strides or less, both feet on space, split pole on lope over.
- F. Skipping over or failing to step in to required space.
- G. Incorrect number of strides.

2 Point Penalties

- A. Break of gait
- B. During the run to the end of arena, failure to change Leads beyond halfway around
- C. Jogging beyond 2 strides, but less than 1/2circle Or 1/2 the arena
- D. Failure to go beyond markers/ or sliding past markers or cones
- E. Freezing up in spins or rollbacks

5 Point Penalties

- A. Spurring in front of the cinch
- B. Use of free hand to instill fear
- C. Holding Saddle with free hand
- D. Kicking Out
- E. Dropping an object required to be carried on course.
- F. First and second refusals
- G. Balk or attempt to evade an obstacle by shying or backing more than 2 strides away
- H. Stepping outside the confines of, falling or jumping off or out of an obstacle with designated boundaries with more than one foot once the foot has entered the obstacle; including missing one element of an element of an obstacle on a line of travel with two feet.
- I. Failure to demonstrate correct gait between obstacle as designated.

-0- Score

- A. Failure to complete Pattern
- B. Performing Maneuvers in unspecified order
- C. Inclusion of additional maneuvers
- D. Equipment Failures
- E. Balking or running away
- F. Jogging more than 1/2 circle or 1/2 Arena length while starting a circle, circling
- G. Over spins of more than 1/4 turn
- H. Fall to ground by horse or rider
- I. More than 1 finger between reins or more than 1 hand on reins except for Junior horses ridden with snaffle/hackamore or mecate with snaffle
- J. Blatant disobedience, bucking, rearing, etc.

Faults not to be considered disqualifications but should be scored according to severity:

- A. Crooked stops & backs
- B. Anticipated stops
- C. Uncontrollable speed
- D. Wringing of tail
- E. Knocking over markers
- F. Failure to run pattern within markers
- G. Failure to go past markers on said pattern
- H. Opening mouth, raising head on stops and turns

Maneuver Description	Trot Serpentine	RL Lope Change	LL Lope to Cone	Walk	Ext. Jog	LL to Center Change	RL Lope Crossover	Stop RBL	Lope Back Crossover	Stop Back	2 Spins R	2 Spins L	HMS	MVT	Penalty Total		
Back #	Penalty																PLACING
	Score																
Back #	Penalty																PLACING
	Score																
Back #	Penalty																PLACING
	Score																
Back #	Penalty																PLACING
	Score																
Back #	Penalty																PLACING
	Score																
Back #	Penalty																PLACING
	Score																
Back #	Penalty																PLACING
	Score																

DATE _____

JUDGES SIGNATURE _____



RANCHMANSHIP PATTERN #4

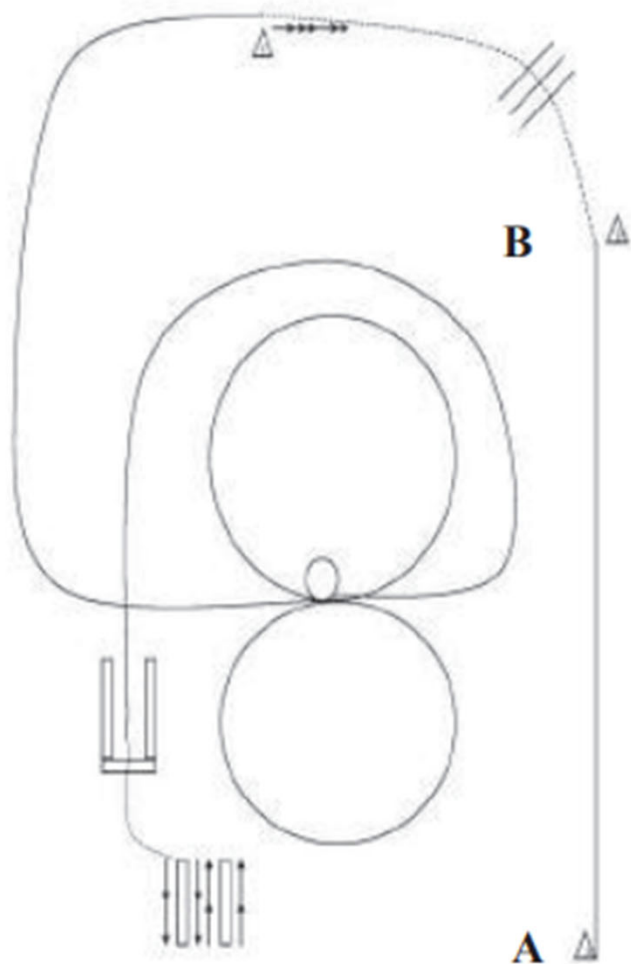

1. Left lead lope A to B.
2. At B break to a trot.
3. Cross Over Poles.
4. Trot to next cone and stop.
5. Back 5 steps.
6. Left lead lope to center, small slow circle.
7. Stop.
8. 2 spins left.
9. Right lead lope small slow; in center change to left lead.
10. Continue to lope left lead into chute; in chute transition to walk.
11. Walk to log and side pass right.
12. Side pass left.

American Ranch Horse Association Ranchmanship Score Sheet

Pattern #4

ARHA rev 2021

Class Name: _____

1/2 Point Penalties:

- A. Failure to remain more than 20 ft from fence when stopping or doing a rollback
- B. Starting a lope departure at a jog or exiting rollbacks up to 2 strides
- C. Delaying lead change by 1 stride
- D. Over or under spinning by 1/8 of a turn
- E. Each tick of a log, pole, cone, or obstacle.
- F. During run around failure to be on correct lead around bend but before half around

1 point Penalties

- A. Each time out of lead deduct 1 point/ accumulative for each 1/4 of circle. See RuleBook
- B. Over or under spinning by 1/4 turn
- C. During rundown to end of arena, failure to change leads beyond 1 stride but prior to next maneuver
- D. Hit or step on log, pole, or obstacle
- E. Break gait at walk or jog 2 strides or less, both feet on space, split pole on lope over.
- F. Skipping over or failing to step in to required space.
- G. Incorrect number of strides.

2 Point Penalties

- A. Break of gait
- B. During the run to the end of arena, failure to change leads beyond halfway around
- C. Jogging beyond 2 strides, but less than 1/2 circle or 1/2 the arena
- D. Failure to go beyond markers/ or sliding past markers or cones
- E. Freezing up in spins or rollbacks

5 Point Penalties

- A. Spurring in front of the cinch
- B. Use of free hand to instill fear
- C. Holding Saddle with free hand
- D. Kicking Out
- E. Dropping an object required to be carried on course.
- F. First and second refusals
- G. Balk or attempt to evade an obstacle by shying or backing more than 2 strides away
- H. Stepping outside the confines of, falling or jumping off or out of an obstacle with designated boundaries with more than one foot once the foot has entered the obstacle; including missing one element of an element of an obstacle on a line of travel with two feet.
- I. Failure to demonstrate correct gait between obstacle as designated.

-0- Score

- A. Failure to complete Pattern
- B. Performing Maneuvers in unspecified order
- C. Inclusion of additional maneuvers
- D. Equipment Failures
- E. Balking or running away
- F. Jogging more than 1/2 circle or 1/2 Arena length while starting a circle, circling
- G. Over spins of more than 1/4 turn
- H. Fall to ground by horse or rider
- I. More than 1 finger between reins or more than 1 hand on reins except for Junior horses ridden with snaffle/hackamore or mecate with snaffle
- J. Blatant disobedience, bucking, rearing, etc.

Faults not to be considered disqualifications but should be scored according to severity:

- A. Crooked stops & backs
- B. Anticipated stops
- C. Uncontrollable speed
- D. Wringing of tail
- E. Knocking over markers
- F. Failure to run pattern within markers
- G. Failure to go past markers on said pattern
- H. Opening mouth, raising head on stops and turns

Maneuver Description	L Lope A-B	Trot at B	Trot poles	Stop at cone	Back 5 steps	LL to Center	Small slow; Stop	2 Spins Left	RL small slow	Change	LL Lope into chute; walk	Walk to log	Sidepass right; Sidepass left	HMS	MVT	Penalty Total	
Back #	Penalty																PLACING
	Score																
Back #	Penalty																PLACING
	Score																
Back #	Penalty																PLACING
	Score																
Back #	Penalty																PLACING
	Score																
Back #	Penalty																PLACING
	Score																
Back #	Penalty																PLACING
	Score																
Back #	Penalty																PLACING
	Score																

DATE _____

JUDGES SIGNATURE _____



RANCHMANSHIP PATTERN #5

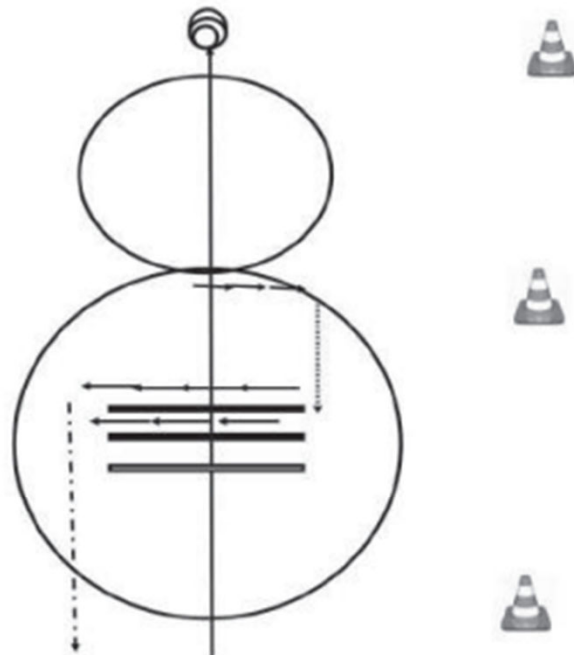

1. Left lead lope down center of arena over poles past the end marker; stop.
2. 3 1/2 spins left.
3. Lope Right lead to center of pen, Turn right lope small slow circle change to left lead.
4. Lope large fast circle stop in center of pen.
5. Back 6-8 feet 90 turn left.
6. Walk to the first pole exhibitor comes to and side passes to the right.
7. Exit at trot to end of arena.

American Ranch Horse Association Ranchmanship Score Sheet

Pattern #5

ARHA rev 2021

Class Name: _____

1/2 Point Penalties:

- A. Failure to remain more the 20 ft from fence when stopping or doing a rollback
- B. Starting a lope departure at a jog or exiting rollbacks up to 2 strides
- C. Delaying lead change by 1 stride
- D. Over or under spinning by 1/8 of a turn
- E. Each tick of a log, pole, cone, or obstacle.
- F. During run around failure to be on correct lead around bend but before half around

1 point Penalties

- A. Each time out of lead deduct 1 point/ accumulative for each 1/4 of circle. See RuleBook
- B. Over or under spinning by 1/4 turn
- C. During rundown to end of arena, failure to change leads beyond 1 stride but prior to next maneuver
- D. Hit or step on log, pole, or obstacle
- E. Break gait at walk or jog 2 strides or less, both feet on space, split pole on lope over.
- F. Skipping over or failing to step in to required space.
- G. Incorrect number of strides.

2 Point Penalties

- A. Break of gait
- B. During the run to the end of arena, failure to change Leads beyond halfway around
- C. Jogging beyond 2 strides, but less than 1/2circle Or 1/2 the arena
- D. Failure to go beyond markers/ or sliding past markers or cones
- E. Freezing up in spins or rollbacks

5 Point Penalties

- A. Spurring in front of the cinch
- B. Use of free hand to instill fear
- C. Holding Saddle with free hand
- D. Kicking Out
- E. Dropping an object required to be carried on course.
- F. First and second refusals
- G. Balk or attempt to evade an obstacle by shying or backing more than 2 strides away
- H. Stepping outside the confines of, falling or jumping off or out of an obstacle with designated boundaries with more than one foot once the foot has entered the obstacle; including missing one element of an element of an obstacle on a line of travel with two feet.
- I. Failure to demonstrate correct gait between obstacle as designated.

-0- Score

- A. Failure to complete Pattern
- B. Performing Maneuvers in unspecified order
- C. Inclusion of additional maneuvers
- D. Equipment Failures
- E. Balking or running away
- F. Jogging more than 1/2 circle or 1/2 Arena length while starting a circle, circling
- G. Over spins of more than 1/4 turn
- H. Fall to ground by horse or rider
- I. More than 1 finger between reins or more than 1 hand on reins except for Junior horses ridden with snaffle/hackamore or mecate with snaffle
- J. Blatant disobedience, bucking, rearing, etc.

Faults not to be considered disqualifications but should be scored according to severity:

- A. Crooked stops & backs
- B. Anticipated stops
- C. Uncontrollable speed
- D. Wringing of tail
- E. Knocking over markers
- F. Failure to run pattern within markers
- G. Failure to go past markers on said pattern
- H. Opening mouth, raising head on stops and turns

Maneuver Description	Rundown Stop	3 1/2 Left	RL Small Slow	Change	LL Large Fast	Stop: Back 6-8 Steps	90L Walk	Sidepass Right	Trot Out							HMS	MVT	Penalty Total		
Back #	Penalty																			PLACING
	Score																			
Back #	Penalty																			PLACING
	Score																			
Back #	Penalty																			PLACING
	Score																			
Back #	Penalty																			PLACING
	Score																			
Back #	Penalty																			PLACING
	Score																			
Back #	Penalty																			PLACING
	Score																			
Back #	Penalty																			PLACING
	Score																			

DATE _____

JUDGES SIGNATURE _____



RANCHMANSHIP PATTERN #6

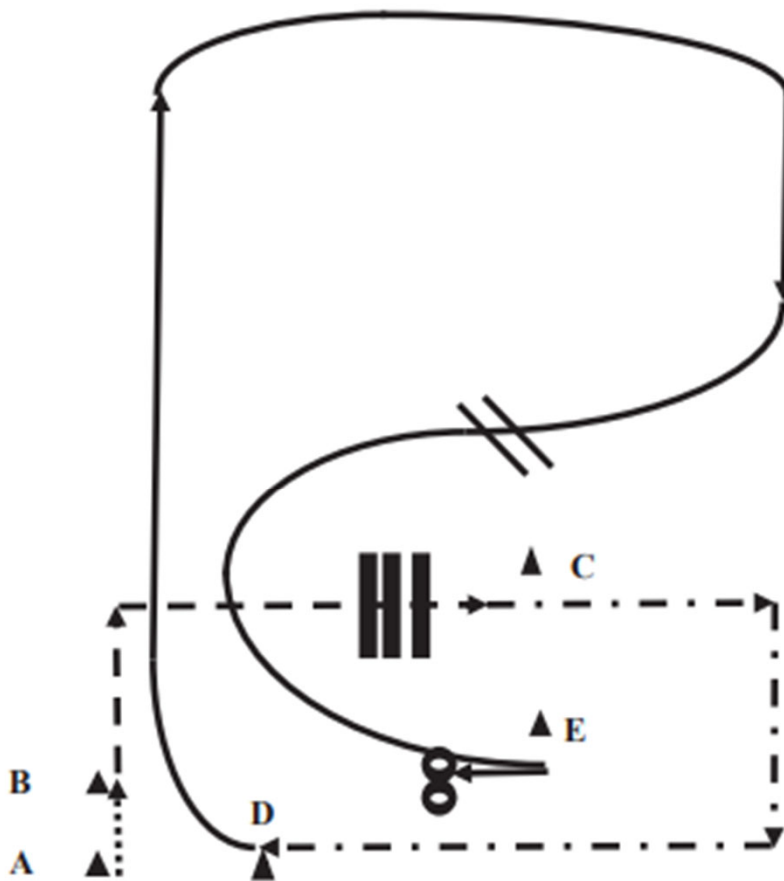

1. Walk from A to B.
2. At B trot over poles to C.
3. At C extended trot to D.
4. Lope right lead up arena and close circle to center and change to left lead.
5. Lope to right side of cone E and stop; back 8 to 10 feet.
6. Two (2) spins to the left.
7. $2\frac{1}{4}$ spins to the right.

American Ranch Horse Association Ranchmanship Score Sheet

Pattern #6

ARHA rev 2021

Class Name: _____

1/2 Point Penalties:

- A. Failure to remain more the 20 ft from fence when stopping or doing a rollback
- B. Starting a lope departure at a jog or exiting rollbacks up to 2 strides
- C. Delaying lead change by 1 stride
- D. Over or under spinning by 1/8 of a turn
- E. Each tick of a log, pole, cone, or obstacle.
- F. During run around failure to be on correct lead around bend but before half around

1 point Penalties

- A. Each time out of lead deduct 1 point/ accumulative for each 1/4 of circle. See RuleBook
- B. Over or under spinning by 1/4 turn
- C. During rundown to end of arena, failure to change leads beyond 1 stride but prior to next maneuver
- D. Hit or step on log, pole, or obstacle
- E. Break gait at walk or jog 2 strides or less, both feet on space, split pole on lope over.
- F. Skipping over or failing to step in to required space.
- G. Incorrect number of strides.

2 Point Penalties

- A. Break of gait
- B. During the run to the end of arena, failure to change leads beyond halfway around
- C. Jogging beyond 2 strides, but less than 1/2circle Or 1/2 the arena
- D. Failure to go beyond markers/ or sliding past markers or cones
- E. Freezing up in spins or rollbacks

5 Point Penalties

- A. Spurring in front of the cinch
- B. Use of free hand to instill fear
- C. Holding Saddle with free hand
- D. Kicking Out
- E. Dropping an object required to be carried on course.
- F. First and second refusals
- G. Balk or attempt to evade an obstacle by shying or backing more than 2 strides away
- H. Stepping outside the confines of, falling or jumping off or out of an obstacle with designated boundaries with more than one foot once the foot has entered the obstacle; including missing one element of an element of an obstacle on a line of travel with two feet.
- I. Failure to demonstrate correct gait between obstacle as designated.

-0- Score

- A. Failure to complete Pattern
- B. Performing Maneuvers in unspecified order
- C. Inclusion of additional maneuvers
- D. Equipment Failures
- E. Balking or running away
- F. Jogging more than 1/2 circle or 1/2 Arena length while starting a circle, circling
- G. Over spins of more than 1/4 turn
- H. Fall to ground by horse or rider
- I. More than 1 finger between reins or more than 1 hand on reins except for Junior horses ridden with snaffle/hackamore or mecate with snaffle
- J. Blatant disobedience, bucking, rearing, etc.

Faults not to be considered disqualifications but should be scored according to severity:

- A. Crooked stops & backs
- B. Anticipated stops
- C. Uncontrollable speed
- D. Wringing of tail
- E. Knocking over markers
- F. Failure to run pattern within markers
- G. Failure to go past markers on said pattern
- H. Opening mouth, raising head on stops and turns

Maneuver Description	Walk A - B	Trot Poles to C	Ext. Trot to D	RL, Top	Change	LL to E	Stop; Back	2 spins L	2 1/4 Right							HMS	MVT	Penalty Total		
Back #	Penalty																			PLACING
	Score																			
Back #	Penalty																			PLACING
	Score																			
Back #	Penalty																			PLACING
	Score																			
Back #	Penalty																			PLACING
	Score																			
Back #	Penalty																			PLACING
	Score																			
Back #	Penalty																			PLACING
	Score																			
Back #	Penalty																			PLACING
	Score																			

DATE _____

JUDGES SIGNATURE _____

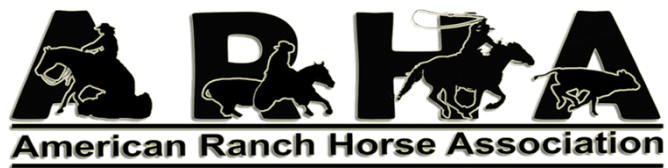

RANCHMANSHIP PATTERN # 7

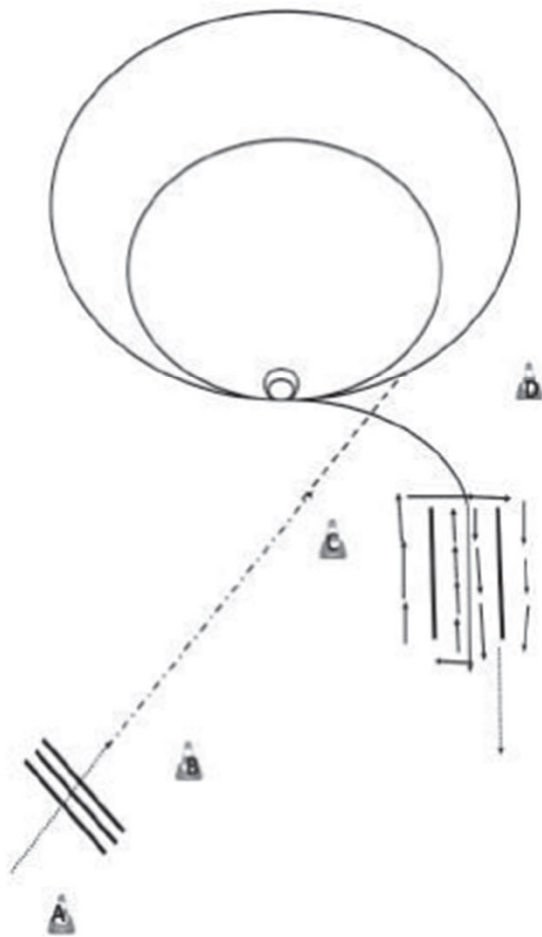

1. Walk from A to B.
2. At B extended trot to C.
3. At C return to trot.
4. At D left lead lope large fast to a small slow and stop in the center.
5. 2 spins left.
6. Trot thru chute, stop, 90 to right.
7. Side pass right.
8. Back to 2nd pole.
9. Side pass left.
10. Walk to exit arena.

American Ranch Horse Association Ranchmanship Score Sheet

Pattern #7

ARHA rev 2021

Class Name: _____

1/2 Point Penalties:

- A. Failure to remain more the 20 ft from fence when stopping or doing a rollback
- B. Starting a lope departure at a jog or exiting rollbacks up to 2 strides
- C. Delaying lead change by 1 stride
- D. Over or under spinning by 1/8 of a turn
- E. Each tick of a log, pole, cone, or obstacle.
- F. During run around failure to be on correct lead around bend but before half around

1 point Penalties

- A. Each time out of lead deduct 1 point/ accumulative for each 1/4 of circle. See RuleBook
- B. Over or under spinning by 1/4 turn
- C. During rundown to end of arena, failure to change leads beyond 1 stride but prior to next maneuver
- D. Hit or step on log, pole, or obstacle
- E. Break gait at walk or jog 2 strides or less, both feet on space, split pole on lope over.
- F. Skipping over or failing to step in to required space.
- G. Incorrect number of strides.

2 Point Penalties

- A. Break of gait
- B. During the run to the end of arena, failure to change Leads beyond halfway around
- C. Jogging beyond 2 strides, but less than 1/2circle Or 1/2 the arena
- D. Failure to go beyond markers/ or sliding past markers or cones
- E. Freezing up in spins or rollbacks

5 Point Penalties

- A. Spurring in front of the cinch
- B. Use of free hand to instill fear
- C. Holding Saddle with free hand
- D. Kicking Out
- E. Dropping an object required to be carried on course.
- F. First and second refusals
- G. Balk or attempt to evade an obstacle by shying or backing more than 2 strides away
- H. Stepping outside the confines of, falling or jumping off or out of an obstacle with designated boundaries with more than one foot once the foot has entered the obstacle; including missing one element of an element of an obstacle on a line of travel with two feet.
- I. Failure to demonstrate correct gait between obstacle as designated.

-0- Score

- A. Failure to complete Pattern
- B. Performing Maneuvers in unspecified order
- C. Inclusion of additional maneuvers
- D. Equipment Failures
- E. Balking or running away
- F. Jogging more than 1/2 circle or 1/2 Arena length while starting a circle, circling
- G. Over spins of more than 1/4 turn
- H. Fall to ground by horse or rider
- I. More than 1 finger between reins or more than 1 hand on reins except for Junior horses ridden with snaffle/hackamore or mecate with snaffle
- J. Blatant disobedience, bucking, rearing, etc.

Faults not to be considered disqualifications but should be scored according to severity:

- A. Crooked stops & backs
- B. Anticipated stops
- C. Uncontrollable speed
- D. Wringing of tail
- E. Knocking over markers
- F. Failure to run pattern within markers
- G. Failure to go past markers on said pattern
- H. Opening mouth, raising head on stops and turns

Maneuver Description	Walk A-B	Ext. Trot to C	Trot at C	LL Lope LF; ss	Slop	2 Spins L	Trot chute	Stop; 90 R	Sidepass R	Back to 2nd pole	Sidepass L	Exit at walk	HMS	MVT	Penalty Total		
Back #	Penalty																PLACING
	Score																
Back #	Penalty																PLACING
	Score																
Back #	Penalty																PLACING
	Score																
Back #	Penalty																PLACING
	Score																
Back #	Penalty																PLACING
	Score																
Back #	Penalty																PLACING
	Score																
Back #	Penalty																PLACING
	Score																

DATE _____

JUDGES SIGNATURE _____



RANCHMANSHIP PATTERN # 8

1. Start at cone, trot over poles to the center of arena and stop.
2. 1 spin right.
3. Right lead lope over pole and run-down arena, stop, roll back to left.
4. Left lead lope small slow.
5. In middle transition to a walk, walk 10 to 15 feet.
6. Stop; back 8-10 feet, 90° turn to left; and trot out of arena.

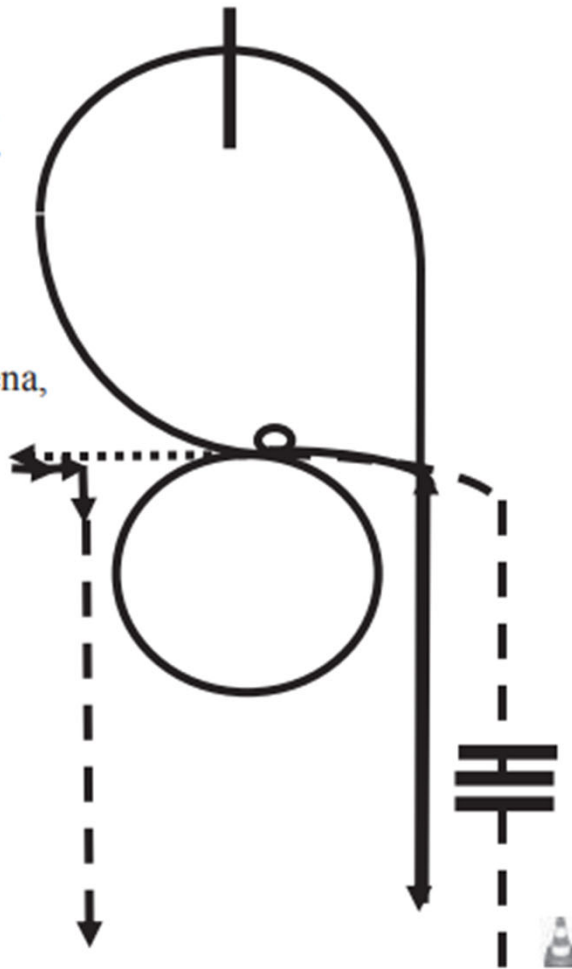

American Ranch Horse Association Ranchmanship Score Sheet

Pattern #8

ARHA rev 2021

Class Name: _____

- 1/2 Point Penalties:**
- A. Failure to remain more the 20 ft from fence when stopping or doing a rollback
 - B. Starting a lope departure at a jog or exiting rollbacks up to 2 strides
 - C. Delaying lead change by 1 stride
 - D. Over or under spinning by 1/8 of a turn
 - E. Each tick of a log, pole, cone, or obstacle.
 - F. During run around failure to be on correct lead around bend but before half around

- 1 point Penalties**
- A. Each time out of lead deduct 1 point/ accumulative for each 1/4 of circle. See RuleBook
 - B. Over or under spinning by 1/8 of a turn
 - C. During rundown to end of arena, failure to change leads beyond 1 stride but prior to next maneuver
 - D. Hit or step on log, pole, or obstacle
 - E. Break gait at walk or jog 2 strides or less, both feet on space, split pole on lope over.
 - F. Skipping over or failing to step in to required space.
 - G. Incorrect number of strides.

- 2 Point Penalties**
- A. Break of gait
 - B. During the run to the end of arena, failure to change leads beyond halfway around
 - C. Jogging beyond 2 strides, but less than 1/2circle Or 1/2 the arena
 - D. Failure to go beyond markers/ or sliding past markers or cones
 - E. Freezing up in spins or rollbacks

- 3 Point Penalties**
- A. Break of gait at walk or jog for more than 2 strides.
 - B. Out of lead or break of gait at lope
 - C. Knocking down or severely disturbing an obstacle.
 - D. Stepping outside the confines of, or falling or jumping off or out of obstacle with one foot. Missing/ evading pole that is part of a series of obstacles.

- 5 Point Penalties**
- A. Spurring in front of the cinch
 - B. Use of free hand to instill fear
 - C. Holding Saddle with free hand
 - D. Kicking Out
 - E. Dropping an object required to be carried on course.
 - F. First and second refusals
 - G. Balk or attempt to evade an obstacle by shying or backing more than 2 strides away
 - H. Stepping outside the confines of, falling or jumping off or out of an obstacle with designated boundaries with more than one foot once the foot has entered the obstacle; including missing one element of an element of an obstacle on a line of travel with two feet.
 - I. Failure to demonstrate correct gait between obstacle as designated.

- 0- Score**
- A. Failure to complete Pattern
 - B. Performing Maneuvers in unspecified order
 - C. Inclusion of additional maneuvers
 - D. Equipment Failures
 - E. Balking or running away
 - F. Jogging more than 1/2 circle or 1/2 Arena length while starting a circle, circling
 - G. Over spins of more than 1/4 turn
 - H. Fall to ground by horse or rider
 - I. More than 1 finger between reins or more than 1 hand on reins except for Junior horses ridden with snaffle/hackamore or mecate with snaffle
 - J. Blatant disobedience, bucking, rearing, etc.

- Faults not to be considered disqualifications but should be scored according to severity:**
- A. Crooked stops & backs
 - B. Anticipated stops
 - C. Uncontrollable speed
 - D. Wringing of tail
 - E. Knocking over markers
 - F. Failure to run pattern within markers
 - G. Failure to go past markers on said pattern
 - H. Opening mouth, raising head on stops and turns

Maneuver Description	Trot poles to center, stop	1 Spin Right	RL lope over pole;	Rundown; stop	Rollback L	LL lope small slow	Trans to walk walk 10-15	Stop: back 8-10	90 L	Trot out	HMS	MVT	Penalty Total	
Back #	Penalty													PLACING
	Score													
Back #	Penalty													PLACING
	Score													
Back #	Penalty													PLACING
	Score													
Back #	Penalty													PLACING
	Score													
Back #	Penalty													PLACING
	Score													
Back #	Penalty													PLACING
	Score													
Back #	Penalty													PLACING
	Score													

DATE _____

JUDGES SIGNATURE _____